

CUSTOMER:

NO.: 2020072503

DISTRIBUTOR:
(PE48AA1)

APPROVE SHEET

[Compliance with RoHS]

PRODUCT: DC BRUSHLESS FAN

USER NO.: _____

Parts No: KF0838B2SK1145JDYRP5

Printed model number on the stick: KF0838B2SKPR

(SIGNATURE)



APPROVED	CHECKED	DRAWN
		郝文姣 2020/07/25



JIANMEI 健策
0755-23706799

1. MECHANICAL:

1-01	Dimension	Dimension of fan shall be shown in the outline styling drawing attached.
1-02	Motor	Four-pole motor.
1-03	Frame	Plastic material UL 94V-0 (P.B.T).
1-04	Impeller	Plastic material UL 94V-0 (P.B.T).
1-05	Free drop shock	In minute package condition, the fan should withstand each one drop of three faces from 30cm distance height onto 10 mm thickness of wooden board.

2.ELECTRICAL: 25°C/65%RH

2-01	Rated current	Rated current shall be measured after 30 minutes continuous rotation at rated voltage.
2-02	Start voltage	The voltage that enable to start the fan by sudden switch on.
2-03	Rated Speed	Rated speed shall be measured after 30 minutes continuous rotation at rated voltage.
2-04	Input Power	Input power shall be measured after 30 minutes continuous rotation at rated voltage.
2-05	Lock Current	Locked current shall be measured Within one minute at rotor locked, after 30 minutes continuous rotation at rated voltage in clear air.
2-06	Insulation resistance	More than 10M ohm at 500 V.D.C between lead and housing.
2-07	Dielectric strength	Measured 5 mA(max) trip current at 700 V.A.C for 3 sec. between lead and housing.
2-08	Locked motor protection	Designed to meet UL, CUL and TUV.

DO NOT use power or ground PWM to control the fan speed.If the fan speed needs to be adjusted,please contact JAMICON to customize the product design for your application.

JIAN 健策

0755—23706799

微信扫码
咨询工程师

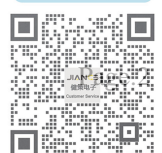

3.CHARACTERISTICS:

3-01	Air Flow & Static Pressure	The air flow data and static pressures should be determined in accordance with AMCA standard or DIN 24163 specification in a double- chamber testing with intake-side measurement.
3-02	Noise level	The measurement of noise level is carried out with reference to DIN 45635 in an echoic chamber with the microphone positioned 1 M from the air intake. Testing fan shall be hung in clean air.

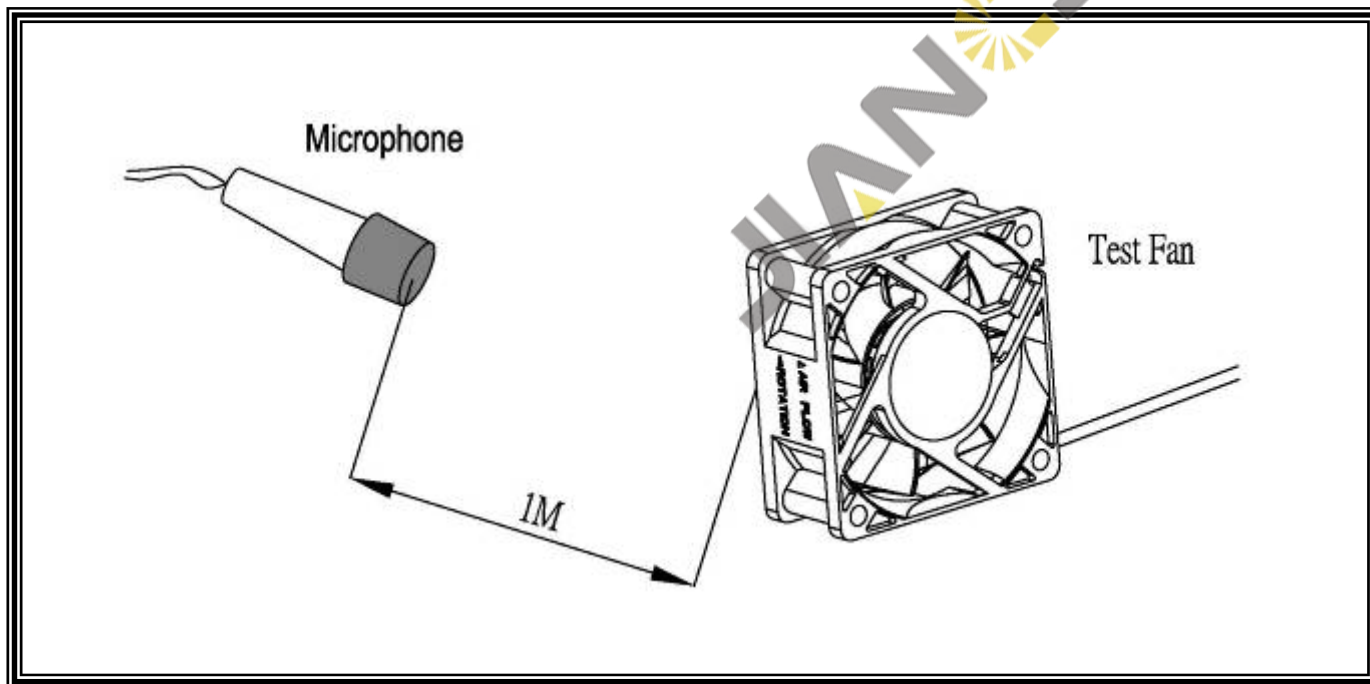

4.ENVIRONMENTAL:

4-01	Operating temperature	-10°C to 70°C (ordinary humidity)
4-02	Storage Temperature	-40°C to 70°C (ordinary humidity)
4-03	Humidity	After 96 hrs, 95% RH 40±2°C per MIL-STD-202F method 103B, Humidity test , The measured data of insulation resistance & dielectric strength should meet the specification listed in attach.
4-04	Thermal Shock	After thermal shock test per MIL-STD-202F method 107D, Condition D, The measured data of insulation resistance & dielectric strength should the specification.

JIAN 健策

0755—23706799

微信扫码
咨询工程师



5.DATA-SHEET:

SAP NO.: K0838B2SK1145JDYP5

PARTW NO.:KF0838B2SK1145JDYRP5

5-1. SPECIFICATION:

NO.	ITEM	SPECIFICATION	UNIT	CONDITION
5-1-01	Dimension	80*80*38	mm	-----
5-1-02	Bearing	Dual Ball	-----	-----
5-1-03	Rated Voltage	24.0	VDC	-----
5-1-04	Operating Voltage	12.0~27.6	VDC	MAX. 27.6V
5-1-05	Start Voltage	12.0	VDC	On/off test max.
5-1-06	Speed	0~6100	R.P.M	At rated Voltage, Duty cycle 0~100%
		6100	R.P.M	At rated Voltage, No PWM Signal
5-1-07	Input Current	0.52	Amp	At rated Voltage Duty cycle 100%
		0.02	Amp	At rated Voltage Duty cycle 0%
5-1-08	Input Power	12.48	Watt	At rated Voltage Duty cycle 100%
		0.48	Watt	At rated Voltage Duty cycle 0%
5-1-09	Nominal Current	0.62	Amp	At rated Voltage, Duty cycle 100%
5-1-10	Air Flow	90.85	CFM	At 0 static Pressure of rated speed
5-1-11	Static Pressure	0.96	inchH ₂ O	At 0 air flow of rated speed
5-1-12	Noise	56.40	dBA	At rated speed
5-1-13	Life Expectancy(L10)	75,000	Hours	At 40°C (Bearing)
5-1-14	Motor protection	Electronic protected		
5-1-15	Polarity protection	It will not damage the fan while reverse input.		
5-1-16	Auto Restart	YES	-----	-----
5-1-17	Speed Signal output	YES(1)	-----	-----
5-1-18	Alarm Signal output	NO	-----	-----
5-1-19	Rotation direction	From the label side	-----	Clockwise
5-1-20	Weight	188	Gram	Per each piece
5-1-21	Safety Certificate	UL, CUL, TUV, CE	-----	-----
5-1-22	IP Rating	IP55		



5-2. LEAD WIRE:

NO.	ITEM	SPECIFICATION			
5-2-01	AWG NO. & Authorize	26AWG, UL1007			
5-2-02	Color	Speed	PWM	=	+
		Yellow	Blue	Black	Red
5-2-03	Line Length	170±10 mm			
5-2-04	Connector	Notes as: Pitch: 2.5 mm Housing: JST XHP-4 compatible parts.			
5-2-05	Tube	Black heat shrinkable tube $\Phi 4.0 \times 150 \pm 5$ mm(needs shrink)			

Note(1): Don't direct connect the speed /Alarm signal output to "+" or "-".

JIAN 健策

JIAN 健策

0755—23706799

微信扫码
咨询工程师



JAMICON FAN PERFORMANCE DATA SHEET

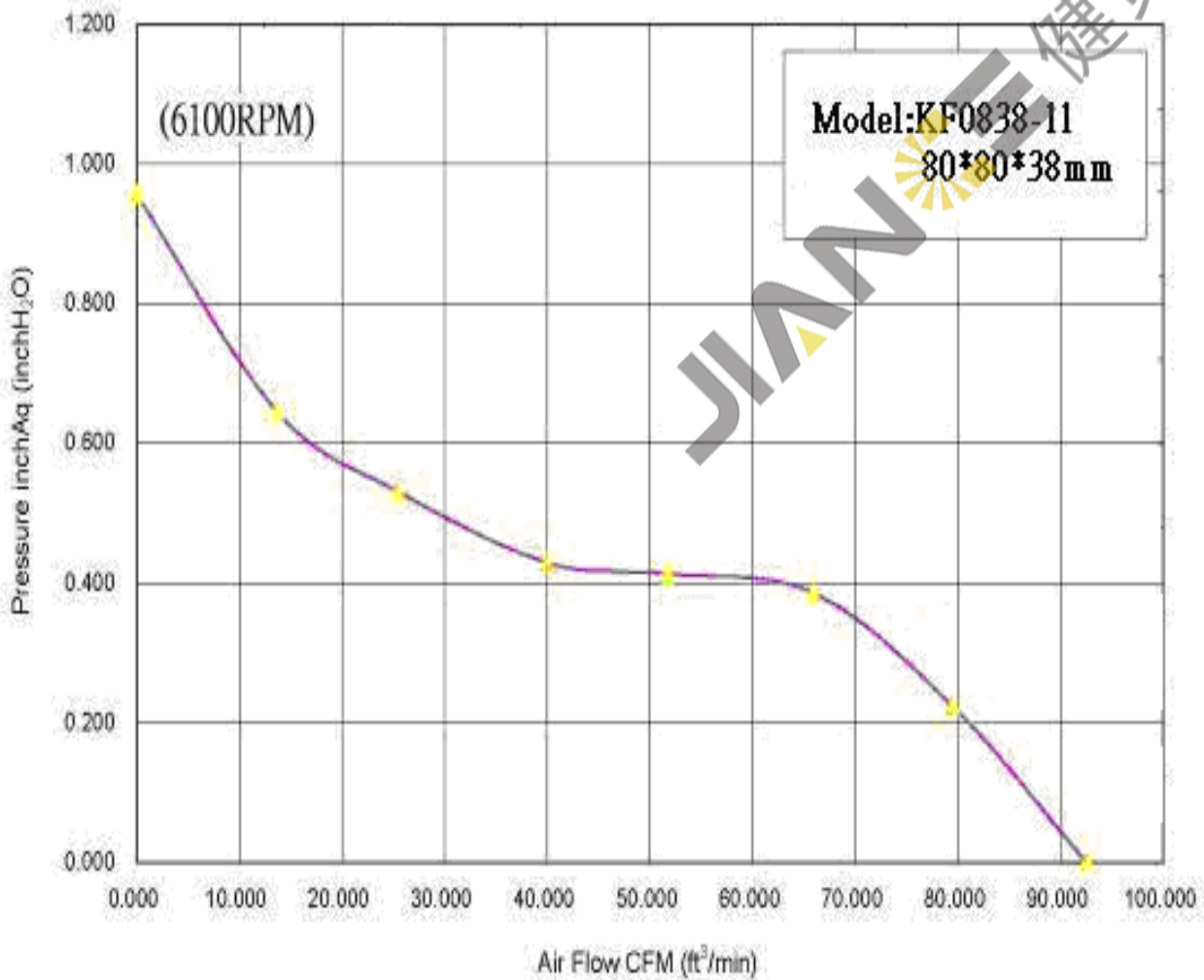

JIAN 健策

JIAN 健策

0755—23706799

微信扫码
咨询工程师



風扇噪音性能測試報告 (The Test Report of Fan Noise)

風扇型號(Sample Type) 0838
 基本規格(properties) DC V 9 葉 4 極
 測試日期(Test Date) 2010 年 9 月 3 日
 測試編號(Tset No.) 001
 測試設備(Test Equip) B&K 2236

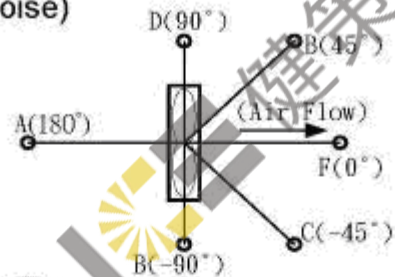

Fulfilis : IEC 651-1979 TYPE1 | IEC 804-1985 TYPE 1
 ANSI S1.4-1983 TYPE S1 ANSI S1.43-199X TYPE 1

測試條件(Test Conditions)

輸入電壓(Input Voltage) V
 量測時間(Measuring Time) 20 Sec
 麥克風距離(Mic. Distance) 100 cm
 麥克風角度(Mic. Angle) 180°
 頻域加權(Freq. Weighting) A
 時域加權(Time Weighting) SLOW
 背景噪音(Background Noise) 15.0 dB(A)
 溫度(Temperature) 31.0 °C
 相對濕度(Relative Humidity) 68.0 %

測試結果(Test Results)

電壓(Passing Voltage)
 電流(Electric Current)
 消耗功率(Power Dissipation)
 轉速(Rotation Speed) 6100 RPM
 均能聲壓位準(Time-averaged SPL + Leq) (依據CNS 8753)
 量測點(At Meas. Point) 56.40 dB(A)
 1米處(At 1m Point) 56.40 dB(A)
 最大聲壓位準(MaxL) 56.80 dB(A)
 最小聲壓位準(MinL) 55.30 dB(A)

聲壓位準頻譜圖(Sound Pressure Level Octave-Band Spectrum)

頻率(Hz)	31.5	63	125	250	500	1k	2k	4k	8k
dB(A)	8.3	12.3	16.2	19.7	31.0	46.3	49.1	51.8	49.9

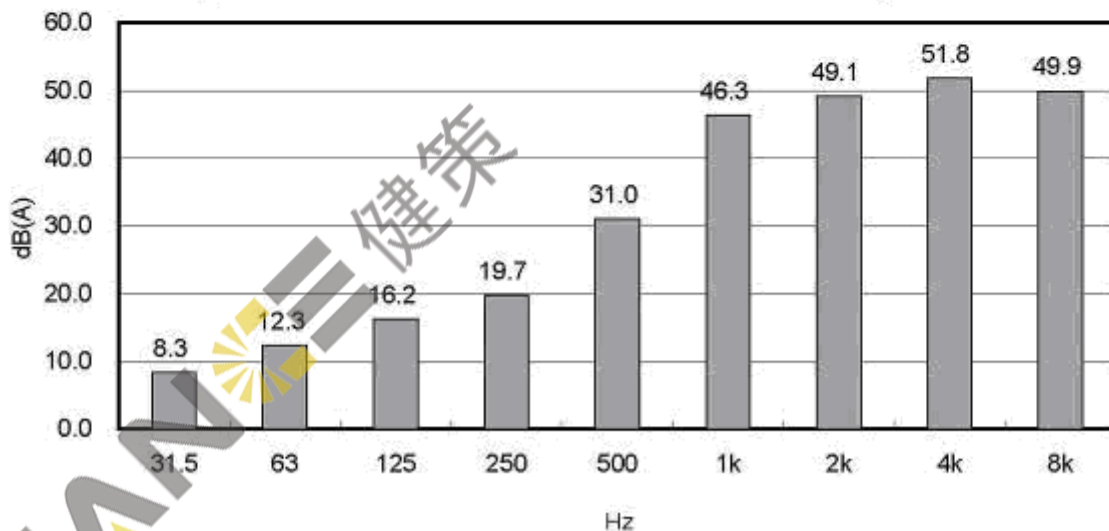

簽核人員：_____

操作人員：周冕寬 Huang-Kuan Chou.

電腦開發(Developer)工業技術研究所機械工業研究所(MFRUTTRI)

JIAN 健策
 0755—23706799

微信扫码
 咨询工程师



KF0838B2SK1145JDYRP5 TEST			
F=21-28KHz VIL≤0.4V VIH=2.8-5.5V			
DUTY CYCLE	Rated Voltage	SPEED (RPM)	RANGE(RPM)
0%	24V	0	不轉
20%		2000	±400
25%		2200	
50%		3800	
75%		5000	±10%
100%		6100	
No PWM Signal		6100	



JIAN 健策

JIAN 健策

0755—23706799

微信扫码
咨询工程师



PWM speed control

PROVISION OF DIGITAL PWM SPEED CONTROL & LOCKED SIGNAL(FG)

OUTPUT OF LOCKED SIGNAL-----OPEN COLLECTOR TYPE

(External signal function design is decided by customer)

CUSTOMER'S CIRCUIT

FAN

CUSTOMER'S CIRCUIT

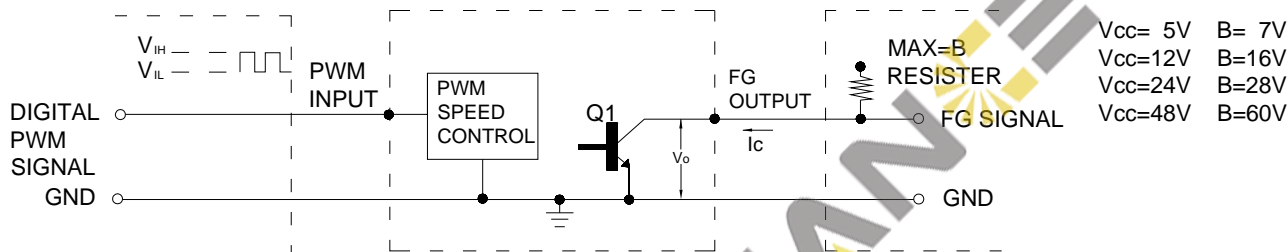

*TRANSISTOR Q1 AT "ON" POSITION

COLLECTOR CURRENT-----Ic= 10MA MAX

SATURATION VOLTAGE-----V_{OL}= 1V MAX

*TRANSISTOR Q1 AT "OFF"POSITION

RELEASE VOLTAGE-----V_{OH} ≅ Vcc

* DIGITAL PWM SPEED CONTROL POSITION

PWM INPUT VOLTAGE HIGH-----V_{IH}= 5.5V MAX

PWM INPUT VOLTAGE LOW-----V_{IL} ≅ 0.4V

PWM INPUT FREQUENCY-----F_{PWM}: 21KHz~28KHz

ROTATION

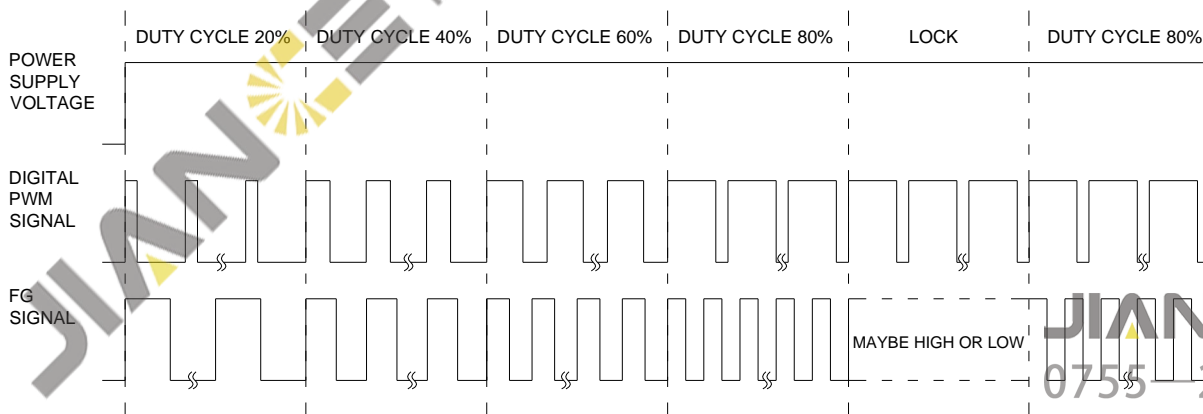

Auto restart /Tachometer signal (Type C)

Diagram:

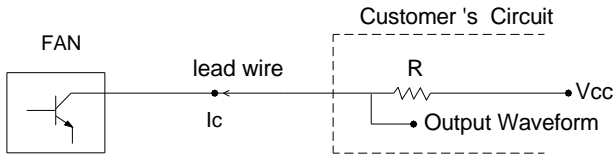

Please select R so that $I_c < 10 \text{ mA}$

Where
Rated Voltage:5V
Vcc:7V max

Where
Rated Voltage:24V
Vcc:28V max

Where
Rated Voltage:12V
Vcc:16V max

Where
Rated Voltage:48V
Vcc:60V max

Type of signal

